

WE-1550-YZL-JD Series High-power Optical Amplifier(with PON Port)



1 Product Overview

WE-1550-YZL-JD optical amplifier uses well-known high-performance erbium-ytterbium co-doped double-clad fiber and low-noise pump laser. It has a reliable circuit design and efficient heat dissipation design. This device adopts a modular design internally and it has high integration. Ultra wide input optical power range, 1RU 19 "height, compatible with EIA racks. The entire machine built-in CWDM can support 32 outputs. The optical switch is available for choice. It provides SNMP protocol network management software and WEB network management, suitable for amplified transmission of downstream 1550nm optical signal in FTTH network.

2 Block diagram

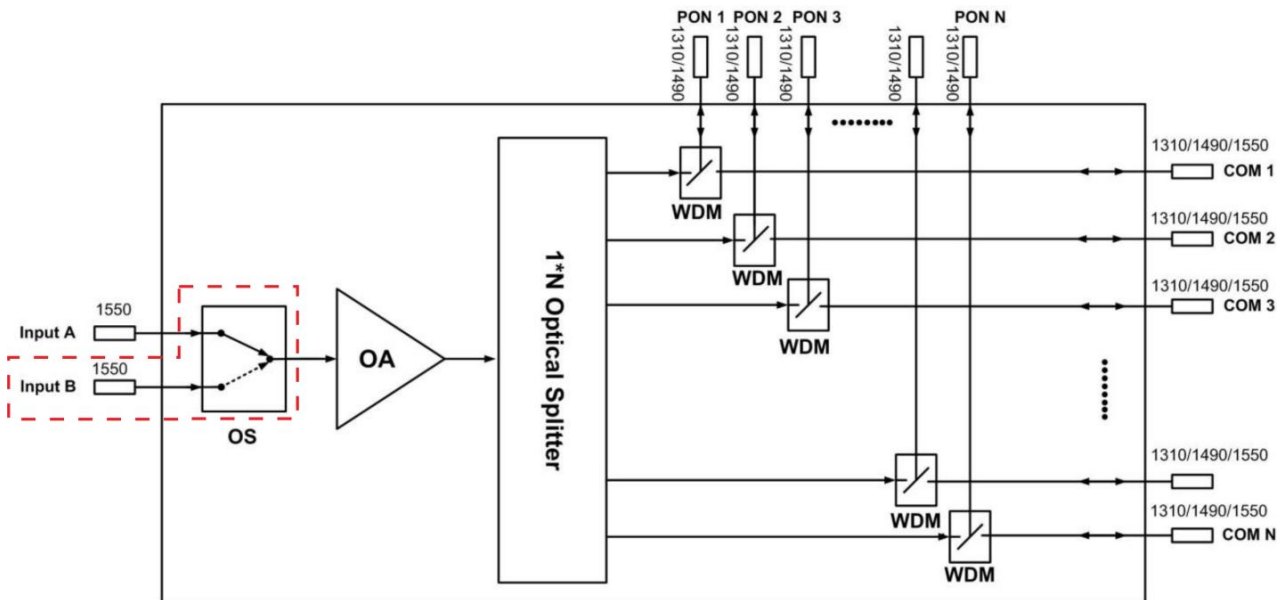

■ Note: The red dashed box above indicates the optional part

3 Technique Parameter

| Item | Unit | Technical Parameters | Notes |
|----------------------------------|------|--|------------------|
| Optical Switch (Optional) | | | |
| Optical Switching time | ms | ≤ 500 | |
| Insertion Loss | dB | ≤1.3 | |
| WDM | | | |
| CATV Pass Through Wavelength | nm | 1545 - 1565 | |
| PON Pass Through Wavelength | nm | 1260 - 1360 & 1480 - 1500 & 1570 - 1580 | Optional (Note1) |
| PON Insertion Loss | dB | < 0.8 | |
| Isolation | dB | > 30 | |
| EDFA | | | |

| | | | |
|-------------------------------------|--------|---|---------------------------------------|
| CATV Input Optical Power Range | dBm | -10 - +10 | |
| Maximum Output Optical Power | dBm | ≤37 | |
| Output power stability | dBm | ≤±0.5 | |
| Noise figure | dB | ≤ 6.0 | Optical input power 0dBm, λ=1550nm |
| Return loss | Input | dB | ≥ 50 |
| | Output | dB | ≥ 50 |
| Pump Leakage to Input Power | dB | ≤-30 | |
| Pump Leakage to Output Power | dB | ≤-30 | |
| Polarization Dependent Gain | dB | < 0.2 | |
| Polarization Mode Dispersion | Ps | < 0.3 | |
| Adjustable Range of Optical Power | dB | 3 | |
| Optical Connector Type | | INPUT port: SC/APC | |
| | | PON ports: SC/UPC or LC/UPC | |
| | | COM ports: SC/APC or LC/APC | |
| Power Supply Voltage | V | AC 100V - 250V (50-60 Hz) DC -36V~-72V | |
| Total Power Consumption | W | ≤ 50 | |
| Operating Temperature Range | °C | -5 - +45 | |
| Maximum Operating Relative Humidity | % | Max. 95% no condensation | |
| Storage Temperature Range | °C | -30 - +70 | |
| Maximum Storage Relative Humidity | % | Max. 95% no condensation | |
| Dimension | mm | 483(L)×275(W)×44(H) | |

Note 1: The default wavelength is GEAPON (1260nm – 1360nm&1480nm – 1500nm). If you need XGPON wavelength (1260nm – 1360nm&1480nm – 1500nm&1570nm – 1580nm), please make a note when ordering.

4 External Function Description

4.1 Front Panel Description

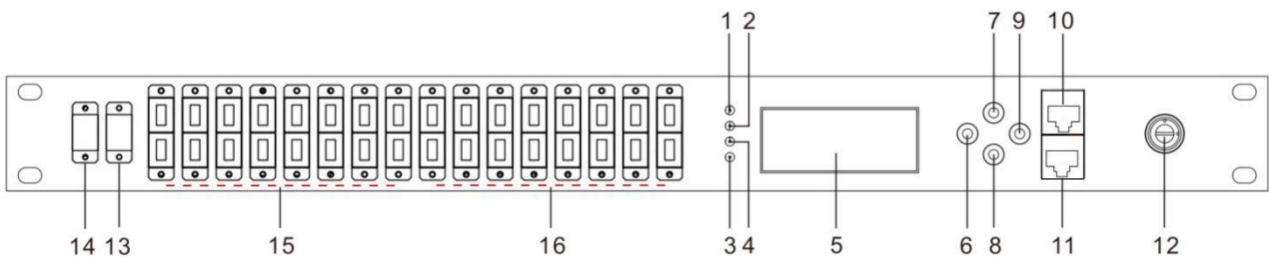

- | |
|--|
| 1. Power indicator: One switching power supply is working – yellow; Two switching power supplies are working – green. Abnormal—flashing red. |
| 2. Optical input power indicator: Normal range— green. Abnormal range—flashing red. |
| 3. Optical output power indicator: Normal range— green. Abnormal range—flashing red. |
| 4. Pump working status indicator: Pump bias, pump temperature, any alarm appears—flashing red. It indicates that the machine has fault Pump laser is working normally— green. |
| 5. 160×32 dot-matrix LCD screen: displays all the parameters of the device. |

| |
|---|
| 6. Display the exit or cancel key of the setup menu. |
| 7. Display the up or increase key of the setup menu. |
| 8. Display the down or decrease key of the setup menu. |
| 9. Display the enter key of the setup menu. |
| 10. RJ45 interface. |
| 11. RS232 interface. |
| 12. Pump laser switching key: "ON" means the pump laser is open and "OFF" means the pump laser is closed. Ensure the key is on "OFF" position before power on. After passing self-test, rotate the key to "ON" position according to the displayed message. |
| 13. Optical signal input A |
| 14. Optical signal input B (Only when the optical switch is selected, the device has this port)(Optional) |
| 15. PON port, max. 16 ports optional. (The diagram above is a schematic diagram, please refer to the silk screen content for the actual configuration.) |
| 16. COM port, max. 16 ports optional. (The diagram above is a schematic diagram, please refer to the silk screen content for the actual configuration.) |

4.2 Rear Panel Description

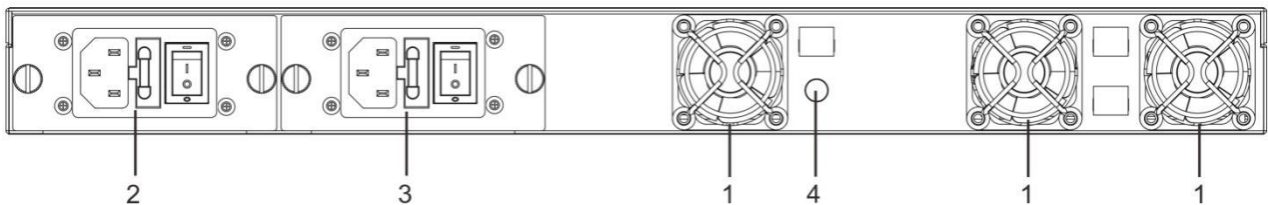

| | |
|-------------------|--------------------------------|
| 1. Fan outlet. | 2. Power supply 1 |
| 3. Power supply 2 | 4. Ground stud of the chassis. |

4.3 DC Power Introduction

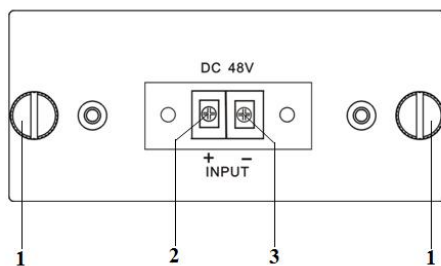

| | |
|---|---------------------------|
| 1 | Mounting screws |
| 2 | + Positive terminal block |
| 3 | - Negative terminal block |

5 Menu System

5.1 Main Menu

| Name | Display | Description |
|-----------------|---------|-------------------------------|
| System Starting | XXXXXXX | Manufacturers' logo |
| | XXXXXXX | Equipment model |
| | XXXXXXX | Start countdown / lock status |

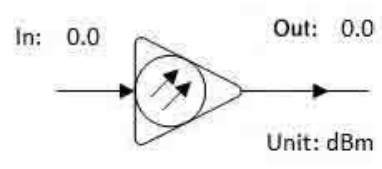
| | | |
|---------------------|---|--|
| Suspend Page |  | Input optical power Output optical power Unit: dBm |
| | Secondary Menu | 1.Disp Parameters 2.Set Parameters 3.Alarm Status |

5.2 Display Menu

| Item | Descriptions |
|----------------------------------|---|
| 1.1 Input Power: xx.x dBm | Input power, accurate to 0.1 dBm |
| 1.2 Output Power: xx.x dBm | Output power, accurate to 0.1 dBm |
| 1.3 PreEDFA Power:xx.x dBm | Pre-stage EDFA optical power, accurate to 0.1 dBm |
| 1.4 Pump1 Bias: x mA | Bias current of pump1, accurate to 1 mA |
| 1.5 Pump1 Temper: xx.x°C | Temperature of pump1, accurate to 0.1°C |
| 1.6 Pump1 Tec: x mA | Cooling current of pump1, accurate to 1 mA |
| 1.7 Pump2 Bias: x mA | Bias current of pump2, accurate to 1 mA |
| 1.8 Pump2 Temper: xx.x°C | Temperature of pump2, accurate to 0.1°C |
| 1.9 +5V Read: x.x V | +5V power supply voltage , accurate to 0.1 V |
| 1.10 System Temper: xx.x °C | The device system temperature, accurate to 0.1 °C |
| 1.11 S/N: xxxxxxxx | Device serial number |
| 1.12 IP Address: xxx.xxx.xxx.xxx | IP address |
| 1.13 Mask:xxx.xxx.xxx.xxx | Subnet mask |
| 1.14 Gateway:xxx.xxx.xxx.xxx | Gateway |
| 1.15 MAC: xxxxxxxxxxxx | Physical address |
| 1.16 Trap Addr1: xxx.xxx.xxx.xxx | trap1 address |
| 1.17 Trap Addr2: xxx.xxx.xxx.xxx | trap2 address |
| 1.18 NTP Addr1 | NTP address1 |
| 1.19 NTP Addr2 | NTP address2 |
| 1.20 UTC Offset | UTC time |
| 1.21 Firmware Ver: Vx.xx.x.x | Firmware version number |

5.3 Setup Menu

| | |
|--------------------------|---|
| 2.1 Low Input Threshold | Set the low optical input power alarm threshold, range -10.0~10.0dBm |
| 2.2 High Input Threshold | Set the high optical input power alarm threshold , range -5.0~10.0dBm |
| 2.3 Set EDFA mode | Set APC or ACC |
| 2.4 Set Output Power | Set the output optical power |
| 2.5 Set IP Address | Set IP address |
| 2.6 Set Mask | Set subnet mask |
| 2.7 Set Gateway | Set gateway |
| 2.8 Set Trap Address1 | Set trap1 |
| 2.9 Set Trap Address2 | Set trap2 |
| 2.10 Set NTP Server1 | Set NTP server1 |
| 2.11 Set NTP Server2 | Set NTP server2 |

| | |
|------------------------|---|
| 2.12 Set UTC Offset | Set UTC offset |
| 2.13 Set Buzzer Enable | Set alarm buzzer switch |
| 2.14 Restore Factory | Restore the factory configuration, set content as shown above |

5.4 Warning menu

| | | |
|-----------------------------|--------------|--|
| Input power: xxx | xxx= LOLOW: | Very low optical input power alarm |
| | xxx= LOW: | Low optical input power alarm |
| | xxx= HIGH: | High optical input power alarm |
| | xxx= HIHIGH: | Very high optical input power alarm |
| Output power: xxx | xxx= LOLOW: | Very low optical output power alarm |
| | xxx= LOW: | Low optical output power alarm |
| | xxx= HIGH: | High optical output power alarm |
| | xxx= HIHIGH: | Very high optical output power alarm |
| System temperature: xxx | xxx= LOLOW: | Very low system temperature alarm |
| | xxx= LOW: | Low system temperature alarm |
| | xxx= HIGH: | High system temperature alarm |
| | xxx= HIHIGH: | Very high system temperature alarm |
| Pump laser current: xxx | xxx= LOLOW: | Very low bias current of pump laser alarm |
| | xxx= LOW: | Low bias current of pump laser alarm |
| | xxx= HIGH: | High bias current of pump laser alarm |
| | xxx= HIHIGH: | Very high bias current of pump laser alarm |
| Pump laser Temperature: xxx | xxx= LOLOW: | Very low temperature of pump laser alarm |
| | xxx= LOW: | Low temperature of pump laser alarm |
| | xxx= HIGH: | High temperature of pump laser alarm |
| | xxx= HIHIGH: | Very high temperature of pump laser alarm |
| Power supply voltage: xxx | xxx= LOLOW: | Very low +5V power supply alarm |
| | xxx= LOW: | Low +5V power supply alarm |
| | xxx= HIGH: | High +5V power supply alarm |
| | xxx= HIHIGH: | Very high +5V power supply alarm |
| Fan | Fan invalid | Failure of any one or multiple fans |
| Invalid power | Left | Left power supply failure |
| | Right | Right power supply failure |

6.Communication Setup Descriptions

6.1 Communication Interface Description

1) Connection Description: RJ45 to DB-9 :

The communication is asynchronous, and the byte frame format is: 1 start bit, 8 data bits, 1 stop bit, no parity; baud rate: 38400 bps.

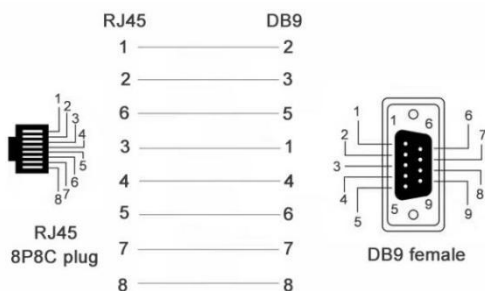

| | RJ45 connector | DB9 female connector |
|-----|----------------|----------------------|
| NO. | 1 | 2 |
| | 2 | 3 |
| | 6 | 5 |
| | 3 | 1 |
| | 4 | 4 |
| | 5 | 6 |
| | 7 | 7 |
| | 8 | 8 |

2) LAN communication interface adopts RJ45 standard connector, the pin definitions as follow:

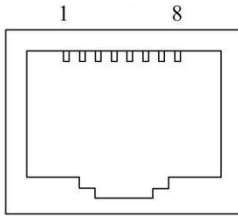

LAN

| | | |
|---------------|---------------|--------|
| 1: TX+ | 2: TX- | 3: RX+ |
| 4: No Connect | 5: No Connect | 6: RX- |
| 7: No Connect | 8: No Connect | |

6.2 WEB Network Management

(1) Opening the IE browser and entering the equipment IP address leads to the following interface:

(2) Enter the user name admin and password 123456 (factory default), to show the following interface:

Optical Amplifier

| Status | status | |
|----------|--------------------|-----------|
| Settings | Input power | -99.9 dBm |
| Network | Output power | 0.0 dBm |
| Update | Pump1 bias | 0 mA |
| Alarm | Pump1 temperature | 25.0 °C |
| About | Pump1 tec | -240 mA |
| | Pump2 bias | 0 mA |
| | Pump2 temperature | 30.0 °C |
| | Device temperature | 29.6 °C |
| | DC +5V | 5.2 V |

There are 6 sub-interfaces:

- 1) Status interface: mainly describes the display menus input and output optical power, pump laser operating bias and temperature, etc.
- 2) Settings interface: some relevant parameters of the device can be set through this interface.
- 3) Network interface: can set the network configuration parameters.
- 4) Update interface: can upgrade the firmware files.
- 5) Alarm interface: can obtain the real-time alarm information by reviewing the alarm log tables.
- 6) About interface: can review the basical information of the EDFA.

(3) Click **Setting** to open the following interface:

Optical Amplifier

| | | |
|--------------------------------------|--------------------------------------|---|
| Status | settings | |
| Settings | Set Output power | 18.3 dB <input type="text"/> dB (15.3~18.3) |
| Network | <input type="button" value="Apply"/> | |
| Update | settings | |
| Alarm | LOW Input Threshold | -5.0 dBm <input type="text"/> dBm |
| About | <input type="button" value="Apply"/> | |
| settings | | |
| | HIGH Input Threshold | 6.6 dBm <input type="text"/> dBm |
| <input type="button" value="Apply"/> | | |
| set pump | | |
| | Set Pump Status | ON <input type="text"/> ON <input type="button" value="v"/> |
| <input type="button" value="Apply"/> | | |
| set work mode | | |
| | Set EDFA Mode | APC <input type="text"/> ACC <input type="button" value="v"/> |
| <input type="button" value="Apply"/> | | |
| restore factory config | | |
| | Restore Factory | <input type="text"/> NO <input type="button" value="v"/> |
| <input type="button" value="Apply"/> | | |
| restart | | |
| | Restart Device | <input type="text"/> NO <input type="button" value="v"/> |
| <input type="button" value="Apply"/> | | |

In this interface, you can set the relevant information as above.

The interface displays the current device value, which can be selected or modified according to actual needs. Click Apply to confirm the update of new parameters.

Steps to change parameters: Find the item that needs to be changed in the item column, then select or enter a new value in the corresponding column, and finally click the corresponding Apply to update the parameters.

(4) Click **Network** to open the following interface:

Optical Amplifier

| | | |
|--------------------------------------|--------------------------------------|--|
| Status | IP settings | |
| Settings | MAC address | 30:71:B5:00:99:88 |
| Network | IP address | 192.168.39.108 |
| Update | Subnet mask | 255.255.255.0 |
| Alarm | Default gateway | 192.168.1.1 |
| About | <input type="button" value="Apply"/> | |
| Web password | | |
| | New UserName | <input type="text"/> |
| | New password | <input type="text"/> |
| | Confirm new password | <input type="text"/> |
| <input type="button" value="Apply"/> | | |
| SNMP settings | | |
| | Read-only community | private |
| | Read-write community | public |
| <input type="button" value="Apply"/> | | |
| SNMP trap address | | |
| | Trap address1 | 192.168.39.105 |
| | Trap address2 | 192.168.1.78 |
| <input type="button" value="Apply"/> | | |
| NTP settings | | |
| | UTC Offset | UTC+1:00 UTC-12:00 <input type="button" value="v"/> |
| | NTP server IP address1 | 85.214.143.181 |
| | NTP server IP address2 | 141.82.25.201 |
| <input type="button" value="Apply"/> | | |

(5) Click **Update** to open the following interface:

Optical Amplifier

| | | | | | |
|-----------------|---|--|--|--|--|
| Status | Update firmware | | | | |
| Settings | Step 1: upload new firmware file | | | | |
| Network | <input type="button" value="Select files"/> No files selected <input type="button" value="Upload"/> | | | | |
| Update | Upload status: awaiting upload | | | | |
| Alarm | Step 2: once upload is successful , restart to update firmware | | | | |
| About | | | | | |

(6) Click **Alarm** to open the following interface:

Optical Amplifier

| | | | | | |
|-----------------|---------------------------|-------------------|--------|-------|--------------|
| Status | Active Alarm Table | | | | |
| Settings | No. | Time | Status | Value | Description |
| Network | 1 | 2025-3-7,13:56:34 | Minor | 1 | Power Number |
| Update | | | | | |
| Alarm | | | | | |
| About | | | | | |

(7) Click **About** to open the following interface:

Optical Amplifier

| | | |
|-----------------|---------------------------|-----------------|
| Status | System information | |
| Settings | Device model | |
| Network | Serial number | SN123456 |
| Update | Firmware version | V1.10.103 |
| Alarm | Uptime | 0 days 00:09:45 |
| About | | |

7 Attention

- Ensure the package is not defaced. If the equipment is damaged due to transportation or other reasons, please don't electrify to avoid worse damage.
- Before powering on, make sure that the grounding terminals of the chassis and power socket are reliably grounded, and the grounding resistance should be $<4\Omega$, which can effectively protect against surges and static electricity.
- Optical amplifier is a highly technical professional equipment, its installation and debugging must be operated by professional technicians. Read this manual carefully before operating to avoid damage to equipment caused by fault operation or accident harm to the operator.
- When installing and debugging optical equipment, invisible laser beams may be emitted inside the fiber connector. Avoiding permanent harm to the body and eye, the fiber connector should not aim at the human body and human should not look directly at the fiber connector with the naked eye!
- There must be no shielding outside the ventilation holes of the device. Poor ventilation will cause the index to decrease, and in serious cases will cause damage to the device.
- When cleaning the fiber end face, you must confirm that the optical source is turned off.
- When the fiber connector is not in use, put a dust cover to avoid dust pollution and keep the end surface of the optical fiber clean.
- When installing the fiber connector, apply appropriate force to avoid damage to the adapter. Otherwise, the output optical power may decrease.

